

# MODEL DVR8550C

## 8.5 HP CENTRAL VACUUM

**TWELVE (12) FILTER BAGS WITH  
52.8 SQ FT FILTER AREA**

LARGE, EASY ACCESS  
FILTER SERVICE DOOR

SUPER EFFICIENT  
FILTRATION

FILTER CONDITION  
INDICATOR GAUGE

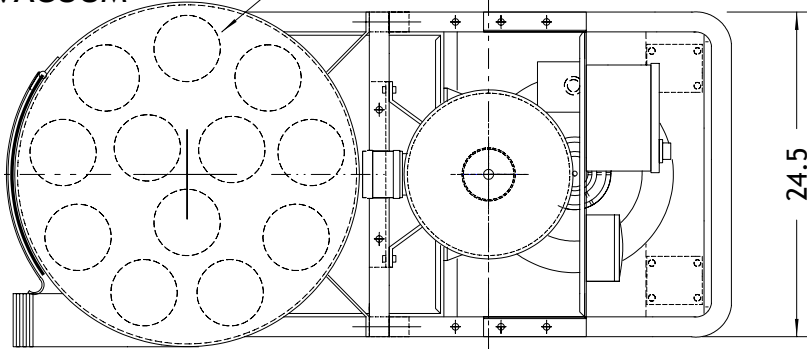

EFFECTIVE  
FILTER BAG  
SHAKER

**FILTERS NEVER  
NEED CLEANING  
AS THE CANISTER  
FILLS.**

OPTIONAL HEPA  
FILTER WITH  
CONDITION  
INDICATOR

OVERHEAD  
CRANE LIFT  
HOOKS

4" NPT  
INLET WITH  
INTERNAL  
WEAR STRIP

29.8 US GAL  
STORAGE DRUM

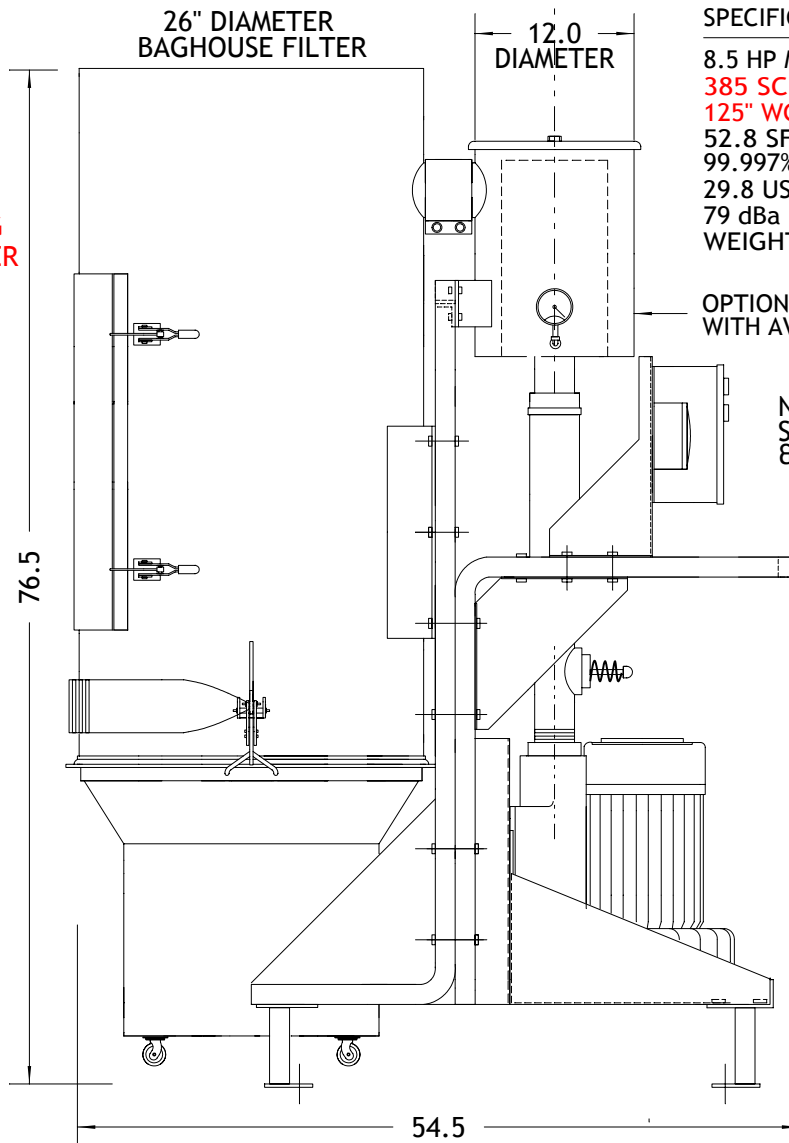

### SPECIFICATIONS:

8.5 HP MOTOR (VOLTAGE TO SUIT)  
**385 SCFM MAX**  
**125" WG MAX VACUUM**  
52.8 SF FILTER BAGS  
99.997% @ 0.4 MICRON EFFICIENT  
29.8 US GALLON STORAGE DRUM  
79 dBa NOISE LEVEL  
WEIGHT 570 LBS

OPTIONAL INLINE FILTER  
WITH AVAILABLE HEPA UPGRADE

NEMA 4  
STARTER PANEL  
& DP GAUGE

VACUUM GAUGE  
& RELIEF VALVE  
STANDARD

HEAVY DUTY ALL  
STEEL FRAME

8.5 HP  
QUIET, DEPENDABLE  
VACUUM PRODUCER

EFFECTIVE, BUILT-IN  
SILENCER

			DATE:	FEB 2004	NORTHWIND AIR SYSTEMS BRAMPTON, ONTARIO
			DRAWN BY:	KRW	
			SCALE:	N.T.S.	
0	FEB 04	ISSUED FOR REVIEW	DRAWING No.	Rev.	<b>DuroVac DVR8550C</b> CONTINUOUS DUTY VACUUM SYSTEM
No.	DATE	REVISIONS	4060333 - 12	00	